

Distributed & Collaborative Worm Detection Experiments



Senthil Cheetancheri, Denys Ma, Jeff Rowe, Karl Levitt

UC Davis

John Mark Agosta, Jaideep Chandrashekar, Denver Dash, Eve Schooler

Intel Corp.

Overview



- Motivation
- Methodology
- Experiments
- Results
- Appendix
 - The Math

Motivation



The Specific Problem



- Often centralized worm defenses are unavailable.
 - Mobile Users
 - Home Offices
 - Small Businesses
 - Network defenses have been bypassed or penetrated
- End-host detectors - last line of defense against large-scale distributed attacks.
- End-host detectors are “weak”
 - Without specific attack signatures, false-positives are high.
 - Local information insufficient to infer a global phenomenon.
- Can ‘weak’ host-based detectors collaborate to produce a ‘strong’ global detector?
- If yes, how such a federation can detect worm attacks?

Our Approach...



- Motivated by
 - Portscan Detection using Sequential Hypothesis Testing
Jung, J., Paxson, V., Berger, A., Balakrishnan, H., “*Fast Portscan Detection Using Sequential Hypothesis Testing*”, Proceedings of the IEEE Symposium on Security and Privacy, 2004
 - Corroborative Intrusion Detection and Inference
Agosta, J.M., Dash, D., Schooler, E., Intel Research
- Designed a Protocol for distributing alert information.
- Developed a Probabilistic model for a federation of end-node detectors to infer worm attacks co-operatively.

Methodology





Distributed Decision Chains (TRW)

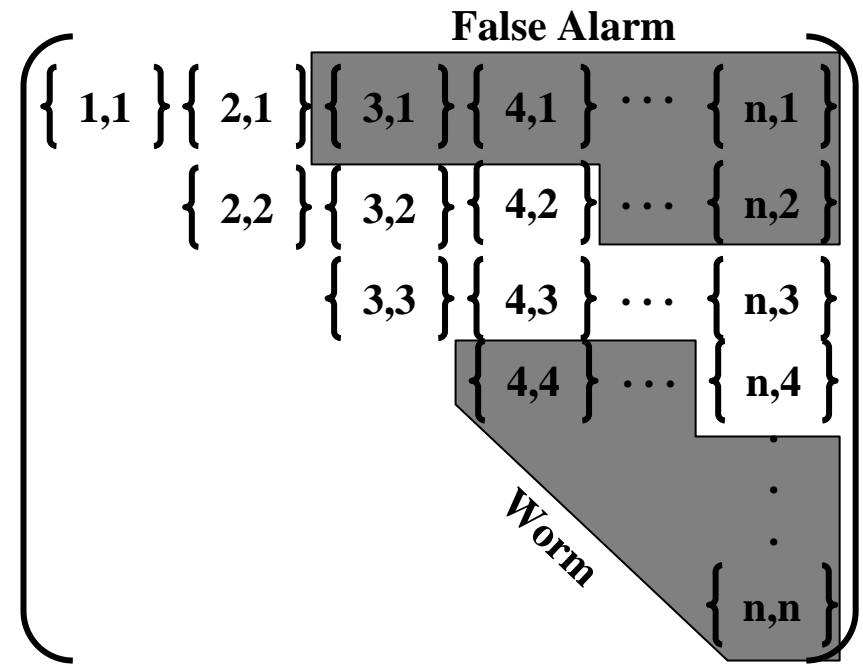
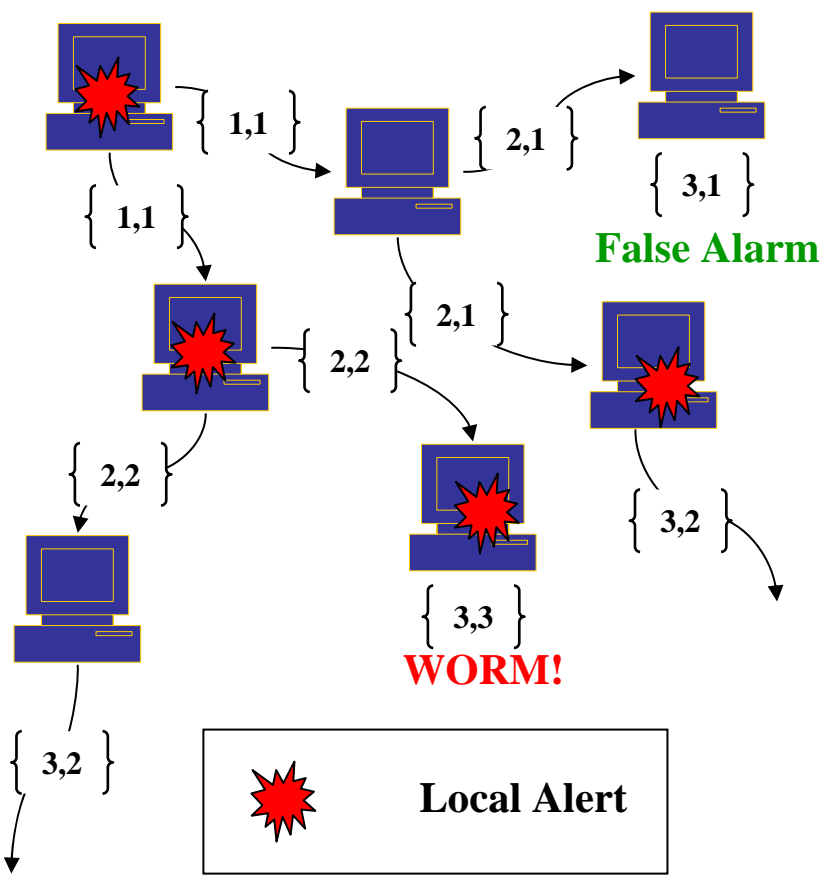

Matrix of Likelihood ratios
Thresholds: T_0, T_1

Protocol Message: $\{i, j, A\}$ - j local alerts for anomaly A seen after i steps

Redundant Testing of Hypothesis

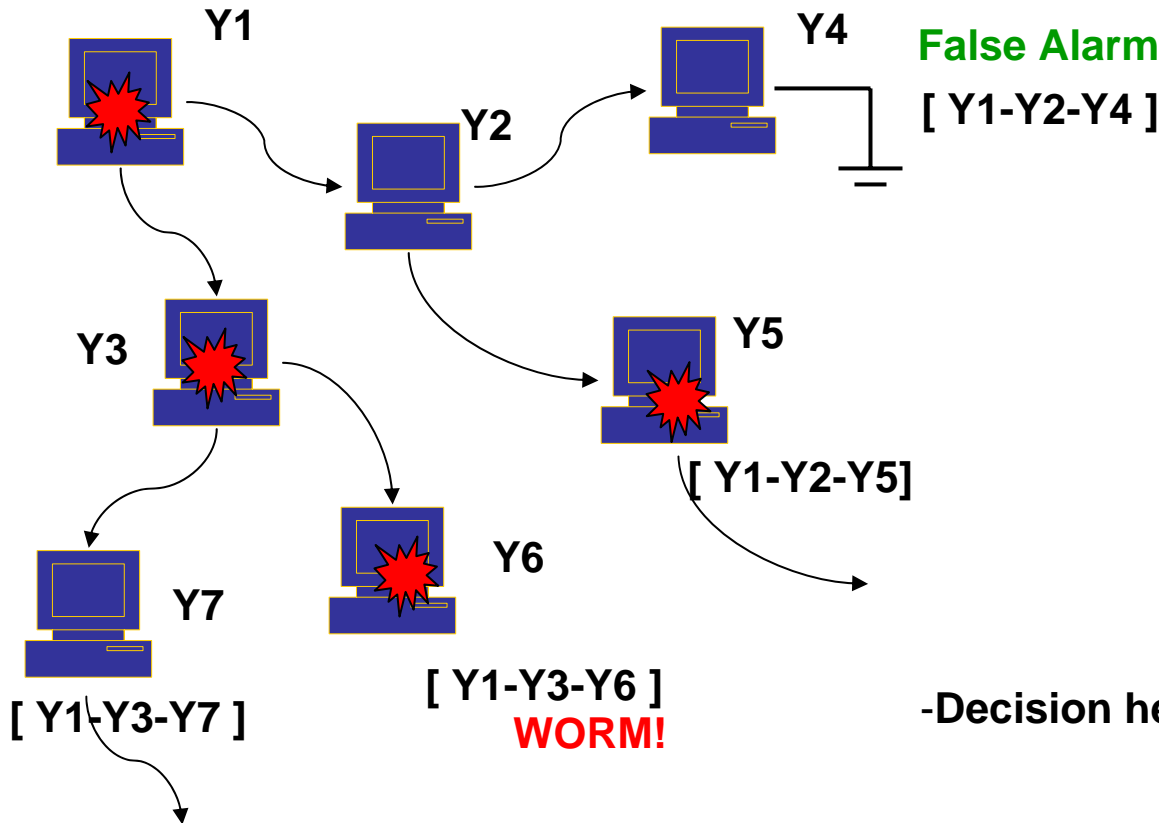

False Alarm

[Y1-Y2-Y4]

[Y1-Y2-Y5]

Tree is efficient but...

-Decision heavily biased on the first couple of nodes

-Redundant information

-Maximize information aggregation / generation



Optimal Testing of Hypothesis

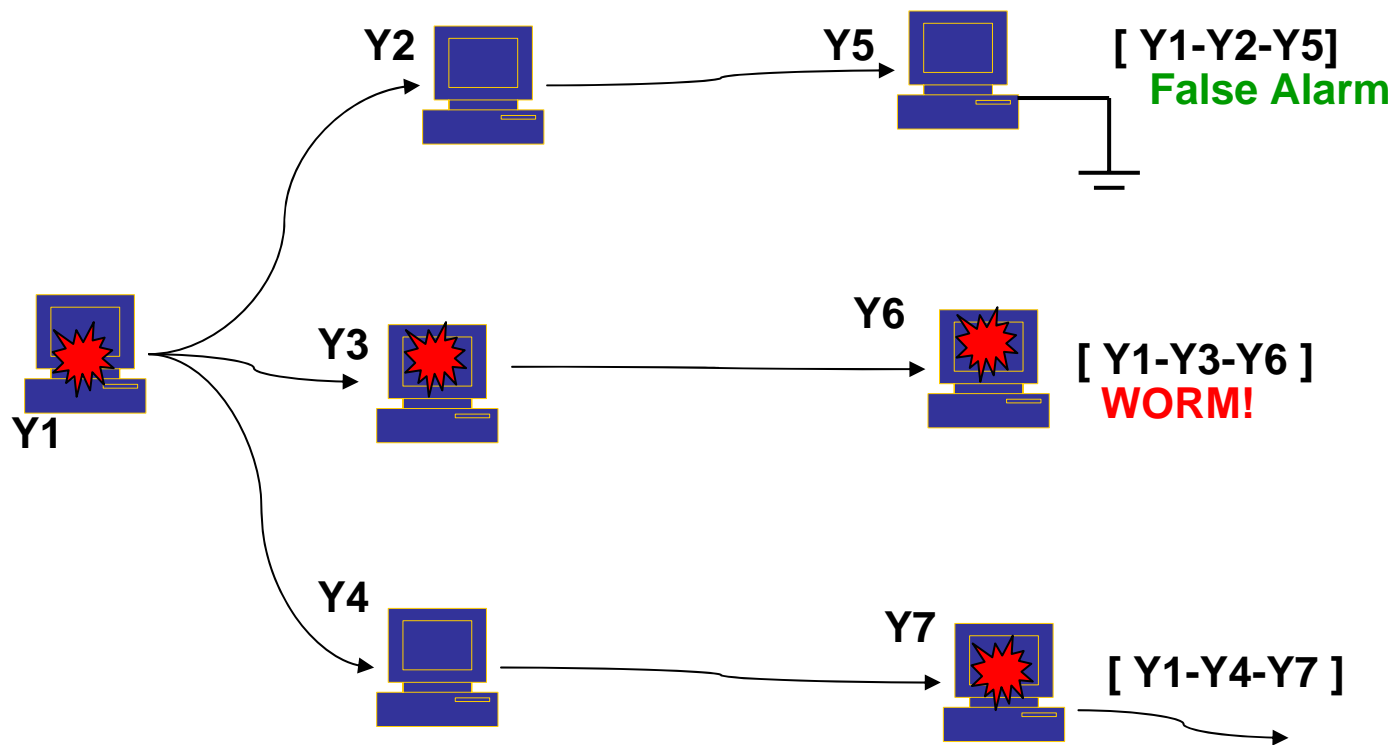

- Each node needs to maintain the partition to be used
- This partition needs to be randomized to avoid targeted attacks
- Memory and computation overhead

Further Optimization

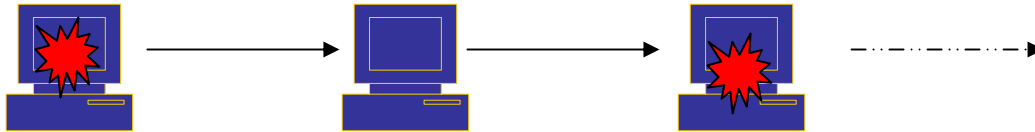

- Just have one chain
- Randomly choose next node

Rationale

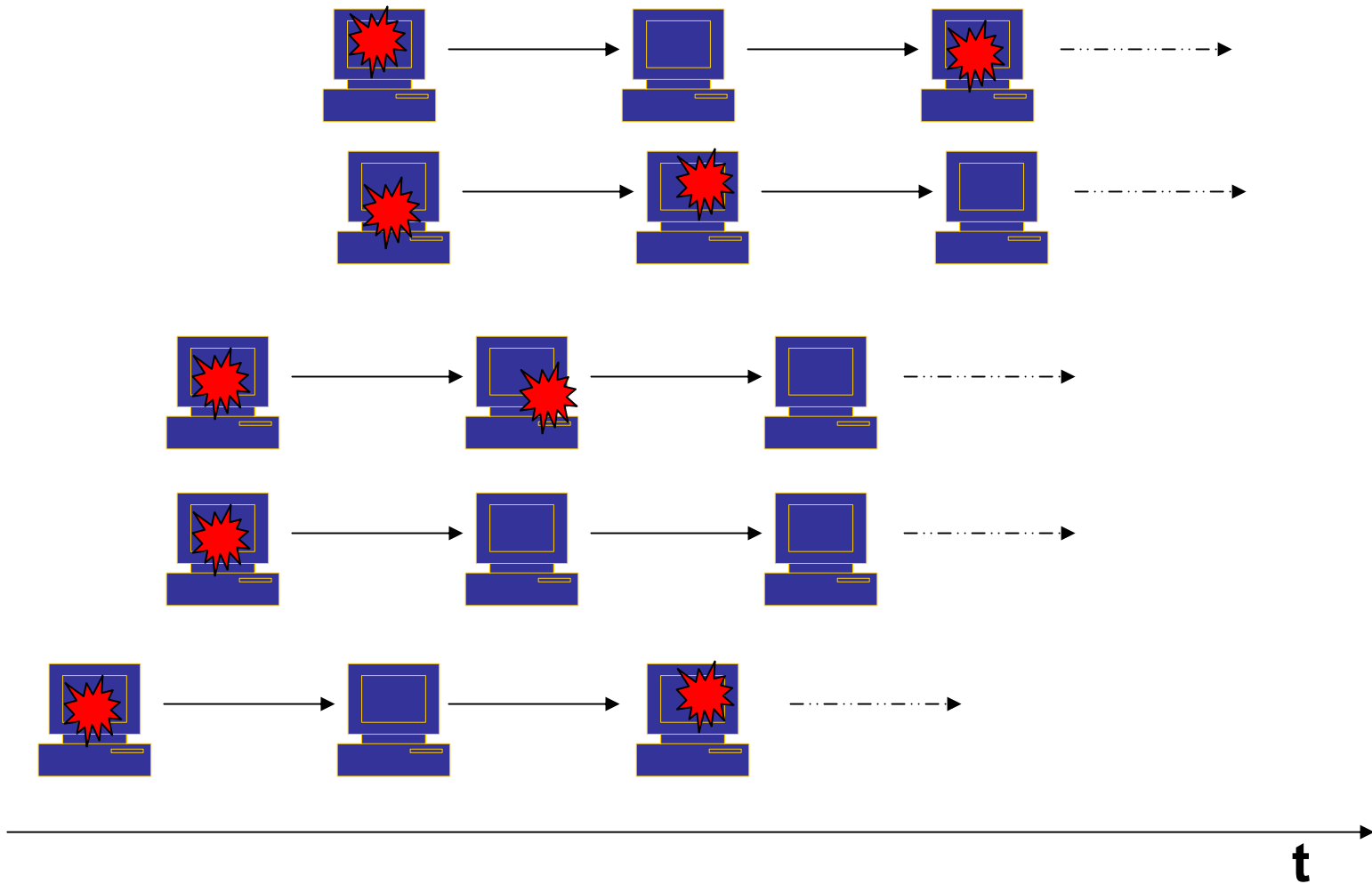

Rationale



- As infection progresses, several parallel chains
- Effect of double counting (redundant info.) is negligible

Experiments & Results



Experimental Set-up



Goal:

- Catch at least 98% of worms
- Miss a maximum of 2% of worms

Resource:

- Weak end-host IDSs
 - raise alarm for every gratuitous connection attempt
- Miss 1% of anomalies (*fn*)
- False positives = variable for each expt. (*fp*)

Worm-Defense Evaluator

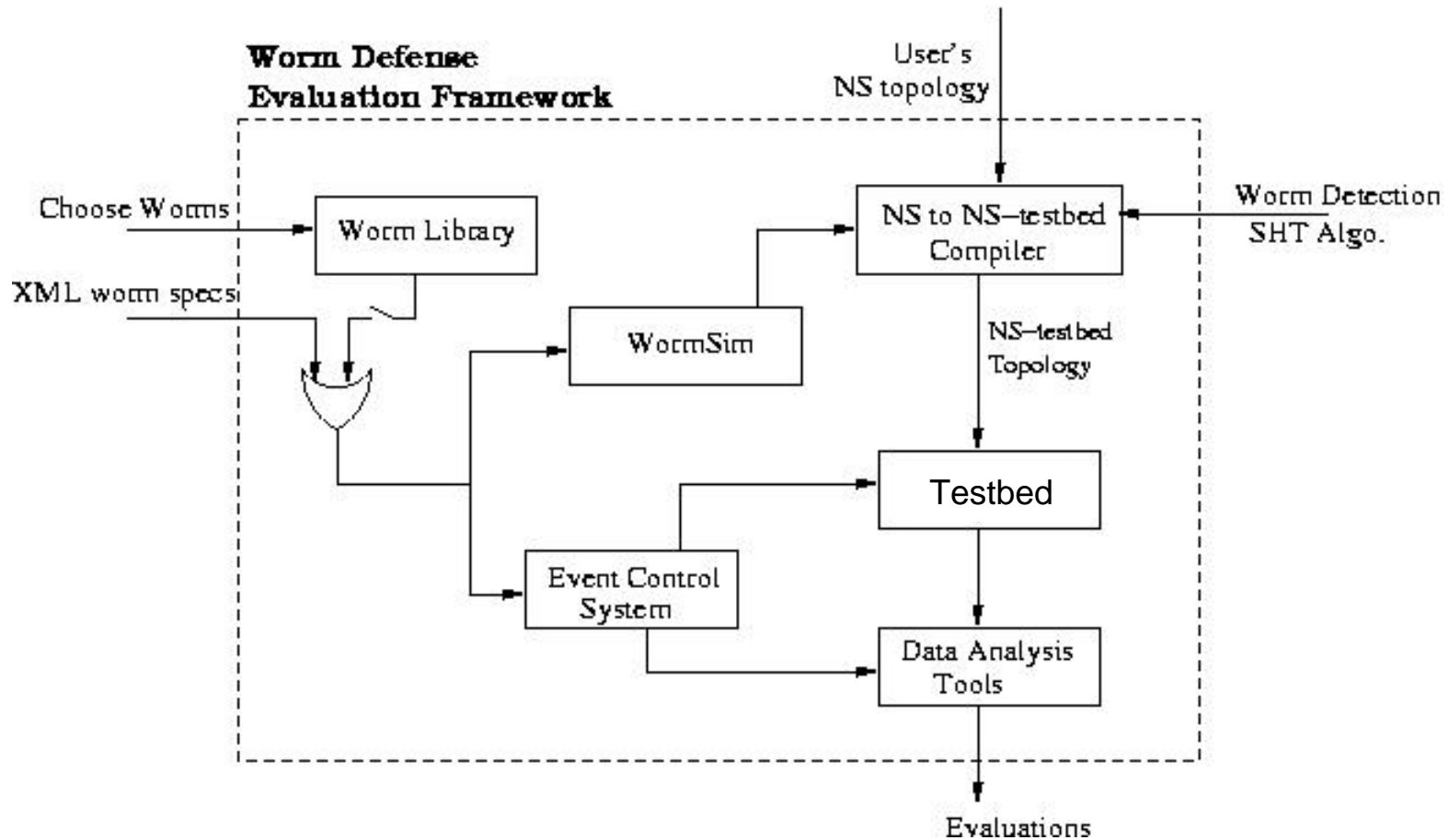

[McAlerney'04], [Malware'06]

Experiment 1- False Alarm Performance



- Traditionally, fp rates are used to test fidelity of IDS.
- We use fp to denote quality of end-host IDSs.
- Several simultaneous distributed false alarms.
 - How many do we need to trick our system?

Crying worm!

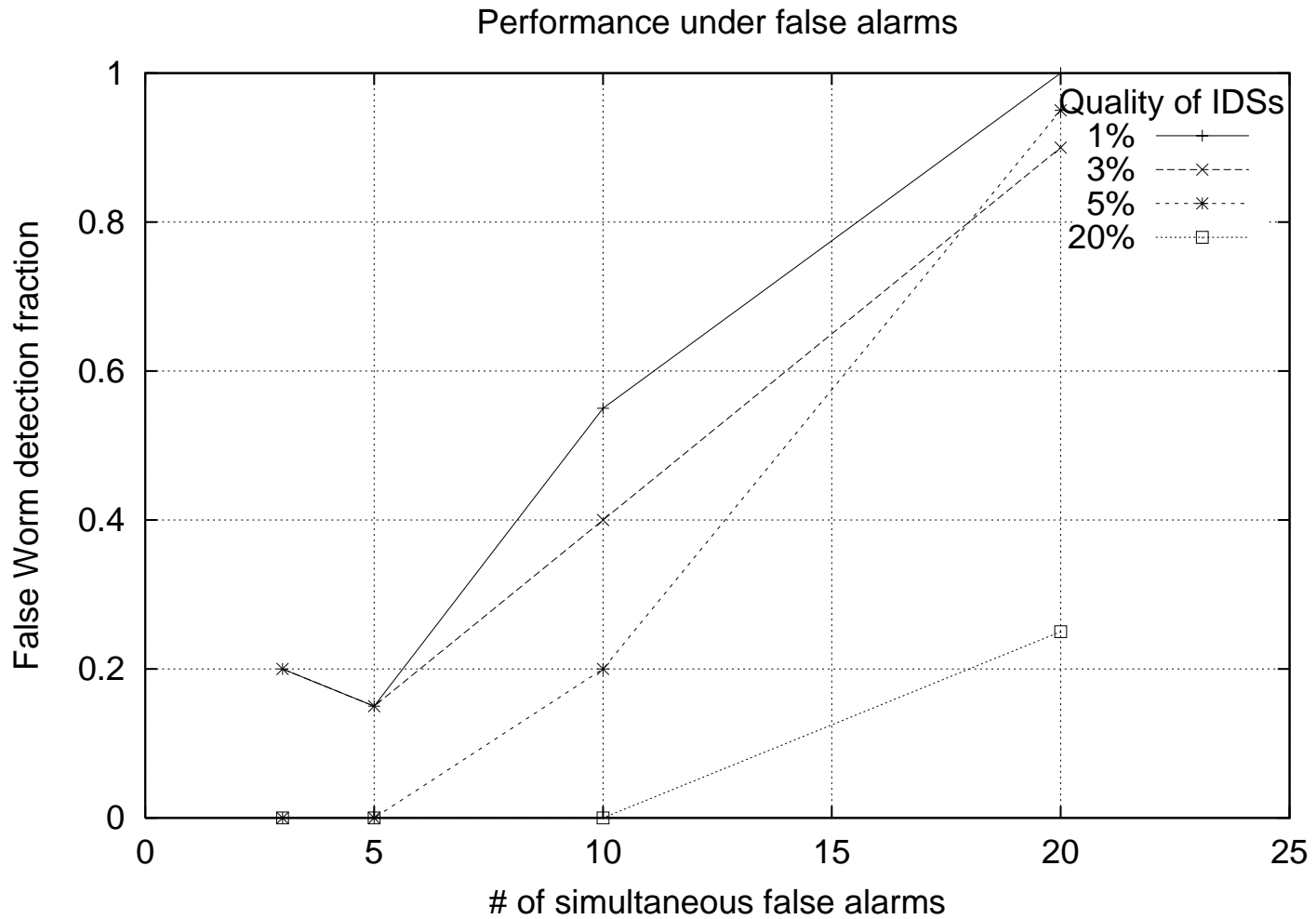

Network Overhead of Protocol



- Bandwidth needed during normal operation
 - # of messages exchanged due to false alarms
- Doesn't vary greatly with the quality of the end-node IDS
- Grow linearly with # of simultaneous false alerts
 - Opposed to quadratic or exponential flood

Protocol Overhead (Bandwidth)

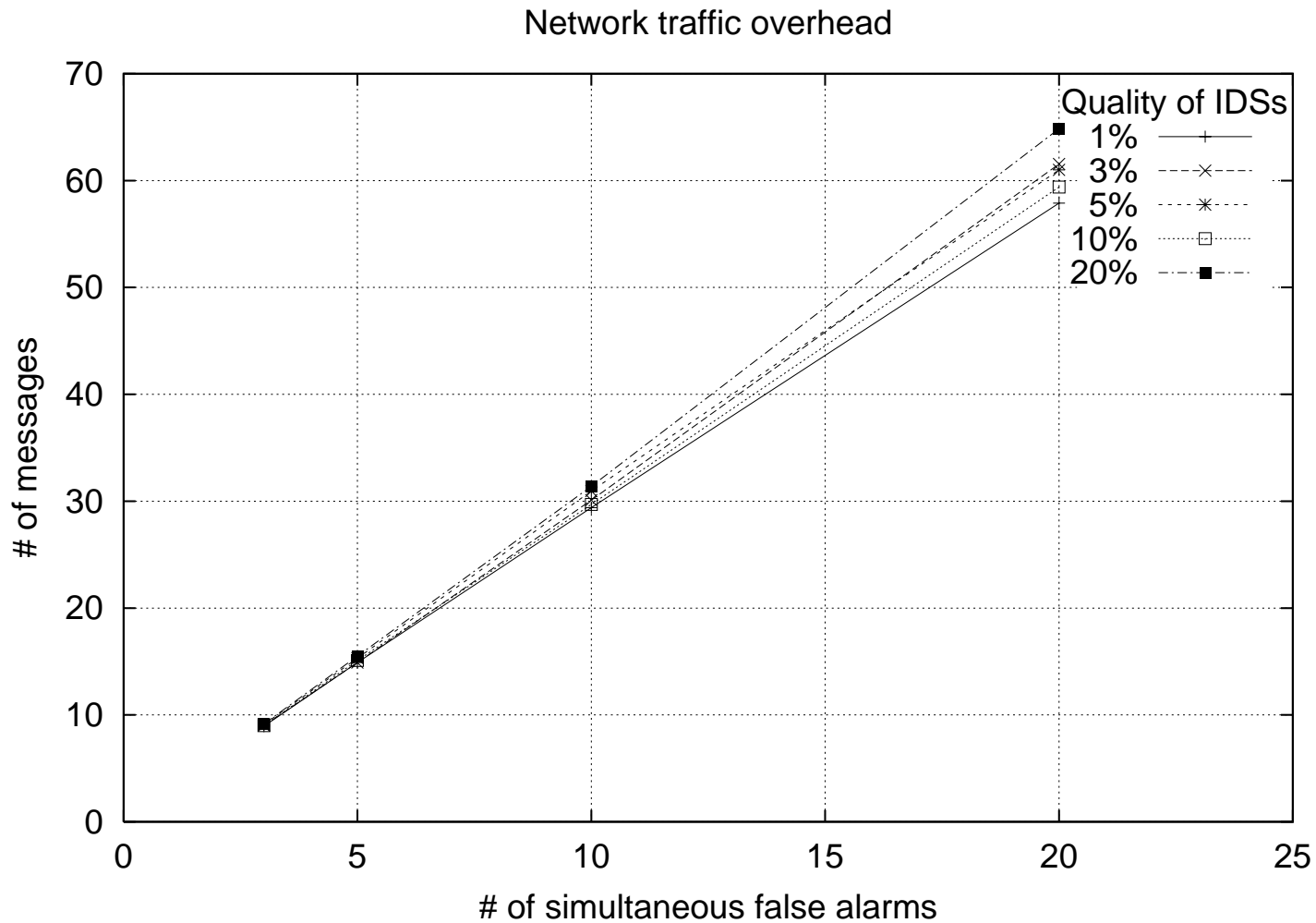

Experiment 2 – Worm Detection



- 25% of participants are vulnerable
- End-node IDS – raise alert for any gratuitous cxns.
- Vulnerable nodes' IDS can't detect attacks
- Random Scans – 1scan /second.

Sample Worm

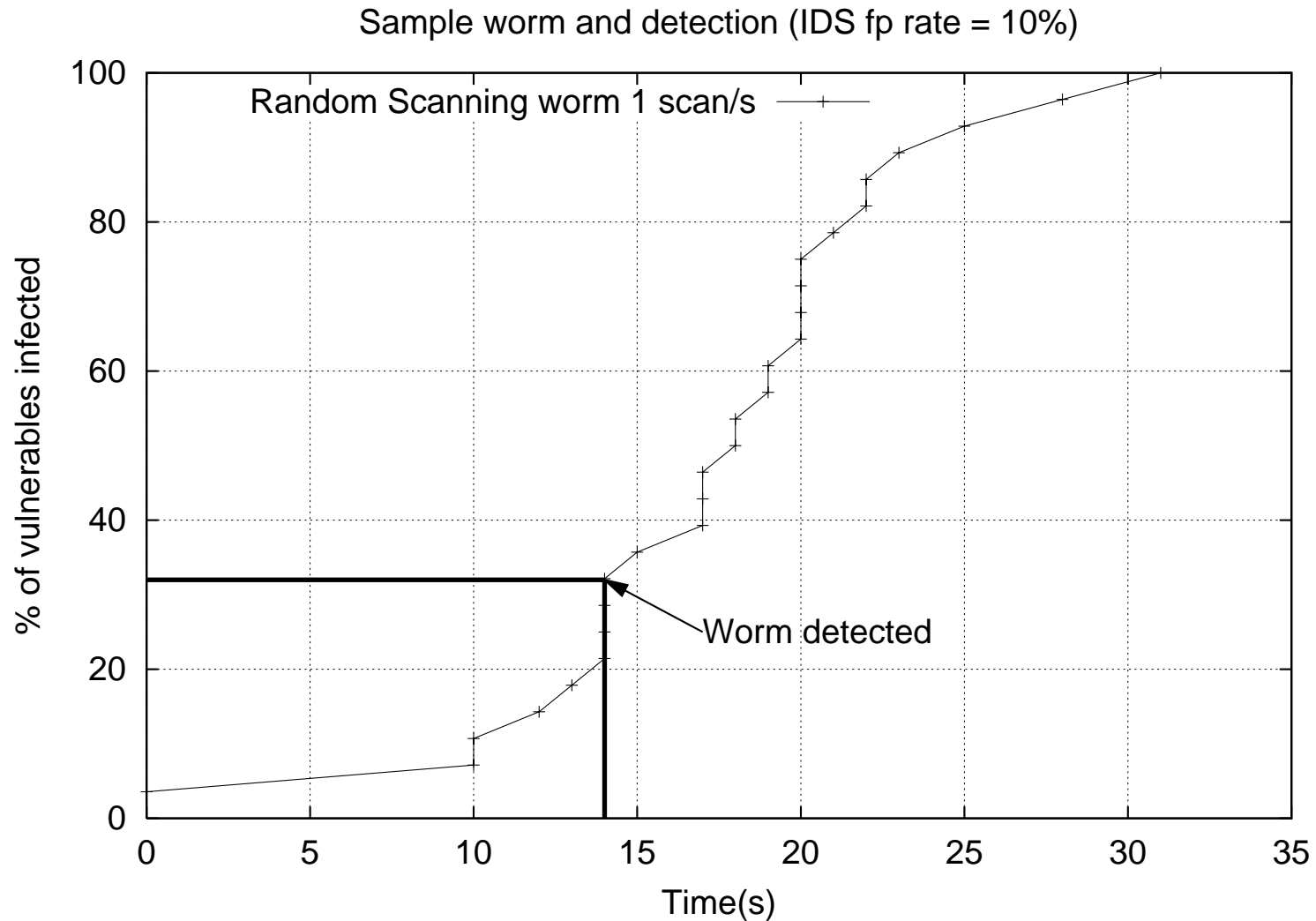

Effectiveness

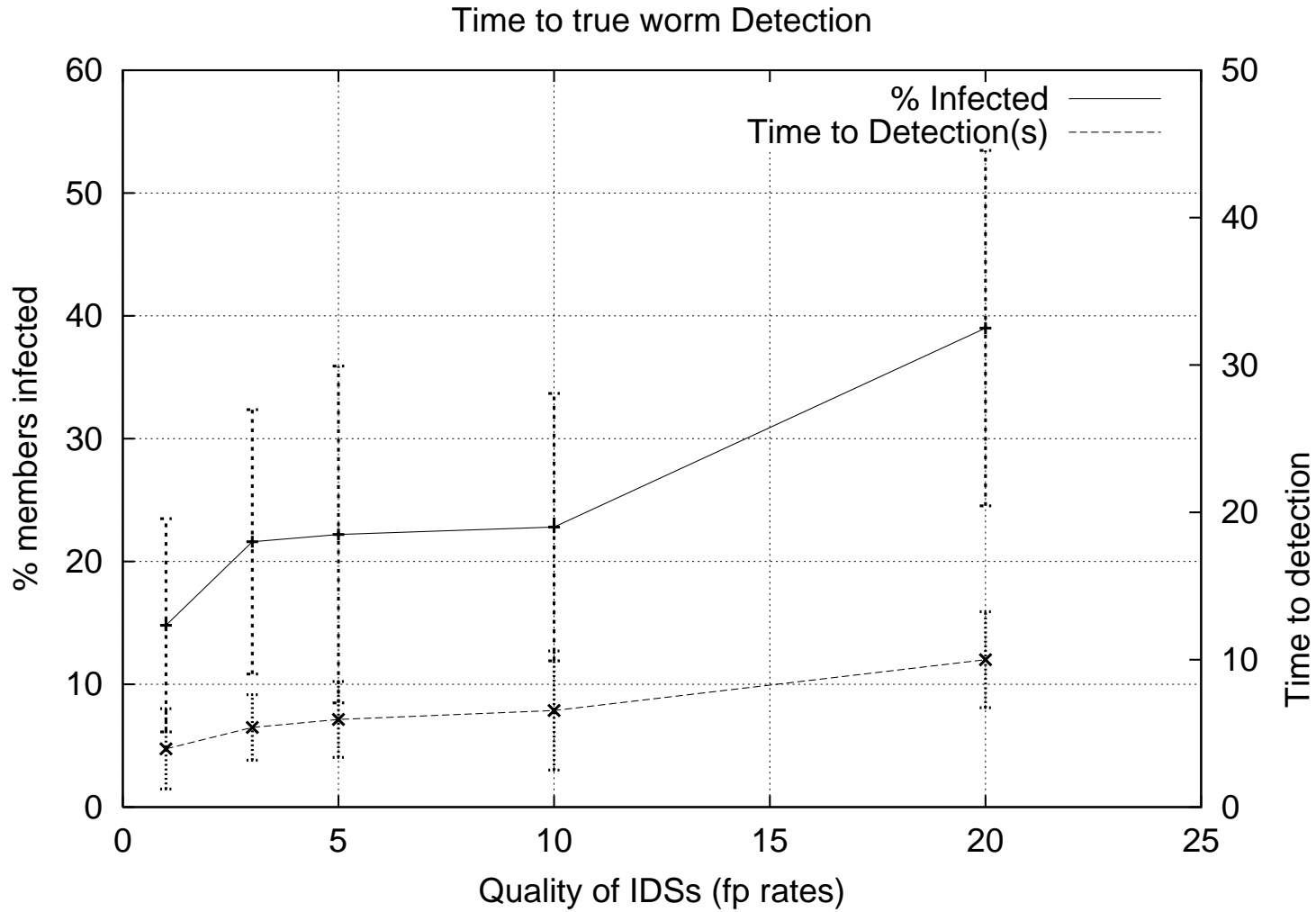

Future Work



- Scale-down node
 - To emulate worm traffic from the rest of the Internet
- Background Traffic
- Anomaly vector

Message



- Unity is Strength !

Papers & Theses



- Wormsim [McAlerney] - MS
- Worm Defense Evaluator [Malware '06]
- Current Work [LSAD '06]